

MENUMASTER[®] Commercial

Project #: _____

Item #: _____

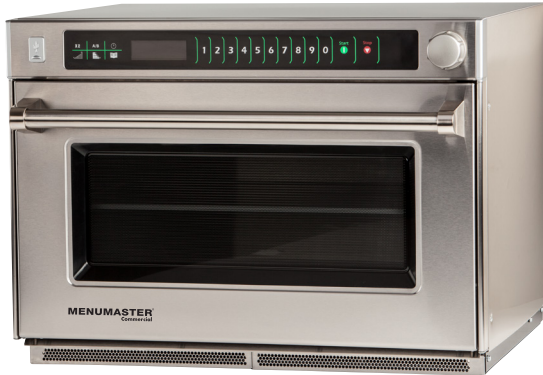

Model MSO5351 shown

Heavy Volume

Menumaster Commercial Microwave Model MSO5351

Power Output

- 3500 watts of power.
- 11 power levels for consistent, delicious results for frozen, refrigerated and fresh foods - from the freezer to table in minutes.
- Unique method of energy distribution provides superior even heating throughout the cavity.

Easy to Use

- Ample 45 liter (1.6 cubic ft.) cavity accommodates two standard 102 mm (4") deep full sized pans.
- Up to 100 programmable menu items can be used to simplify cooking and ensures consistent results.
- USB port compatible with standard flash drives, updates programming in seconds.
- Four stage cooking options with one-touch programming. Reduces prep time, labor and food waste while providing consistent results.
- Controls are user friendly and require minimal training.
- Quantity pad calculates the proper cook times for two servings.
- See-through door and lighted interior for monitoring without opening the door.
- Interior ceramic shelf is recessed to reduce plate-to-shelf edge impact and keep spills contained.

Easy to Maintain

- Stainless steel exterior and interior for easy cleaning and a professional look.
- Constructed to withstand the foodservice environment.
- Magnetic front air filter for easy removal and cleaning.
- Clean filter reminder to protect oven components.

Heavy Volume

This category of microwave is ideal for...

Applications:

- Schools
- Healthcare Facilities
- Buffets
- Cafeterias
- Stadiums
- Supermarkets
- Fast Casual Restaurant

Defrost:

- Defrosts most frozen food products

Throughput Potential:

- 4.5 kg (10 lb.) baby red potatoes, 5 per hour
- 3.5 kg (8 lb.) frozen vegetables, 6 per hour
- 1 kg (2 lb.) shrimp, 24 per hour

All ACP, Inc. commercial ovens are backed by our Culinary Center. Call us with any question regarding food preparation, menu development and cooking times. 866-426-2621.



AIA File #:

Specification #:



MenuMaster Commercial Microwave Model MSO5351 | Heavy Volume

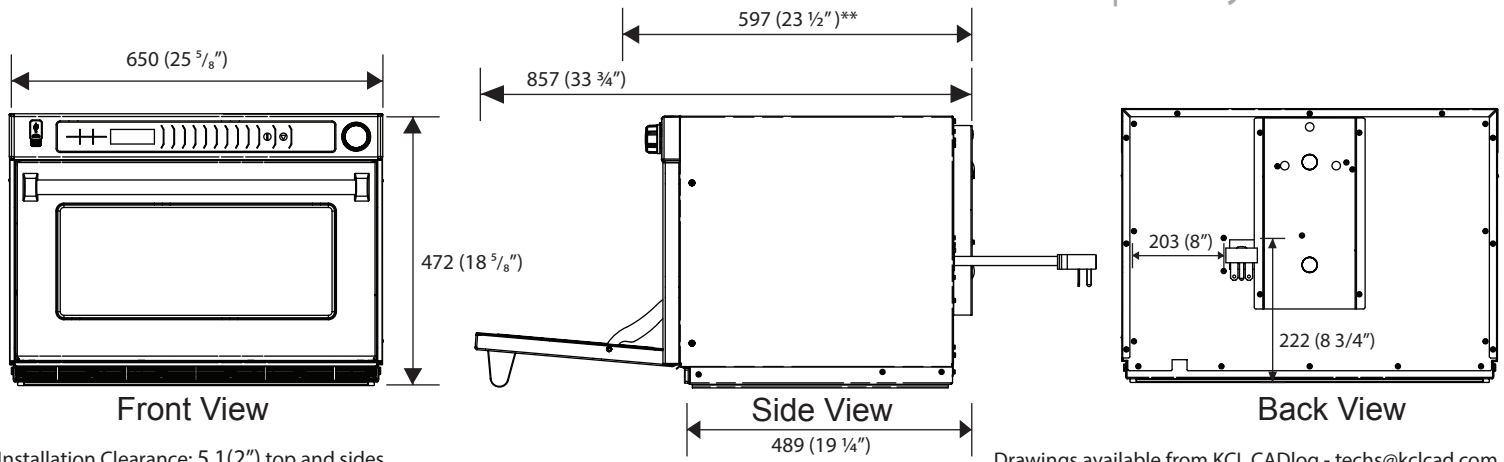

Installation Clearance: 5.1(2") top and sides

Drawings available from KCL CADlog - techs@kclcad.com

Specification #:

Specifications			
Model	MSO5351	UPC Code	728028315837
Configuration	Countertop		
Control System	Touch w/ dial		
Programmable Control Pads	10		
Settings Programmable	100		
Max. Cooking Time	60 minutes		
Power Levels	11		
Defrost	Yes, power level 2		
Dial Time Entry	Yes		
Time Entry Option	Yes		
Microwave Distribution	Top and bottom antennas		
Magnetrons	4		
Display	LCD		
Stage Cooking	Yes, 4		
Interior Light	Yes, LED		
Door Opening	Pull down		
Door Construction	Window		
Latch Number	2		
Window Material	Glass		
Air Filter w/Reminder	Yes		
Stackable	Yes		
Signal	Yes		
Automatic Voltage Sensor	No		
Multiple Portion Setting	Yes, x2		
Exterior Dimensions	H 472 (18 5/8")	W 650 (25 5/8")	D** 597 (23 1/2")
Cavity Dimensions	H 251 (9 7/8")	W 535 (21")	D 330 (13")
Door Depth	857 (33 3/4"), drop down door		
Usable Cavity Space	45 liter (1.6 cubic ft.)		
Exterior Finish	Stainless steel		
Interior Finish	Stainless steel with recessed ceramic tray and removable shelf		
Power Consumption	5400 W		
Power Output*	3500 W* Microwave		
Power Source	230V, 50 Hz, 30A single phase		
Plug Configuration / Cord	IEC 309	1.5m (5 ft.)	
Frequency	2450 MHz		
Product Weight	66 kg. (146 lb.)		
Ship weight (approx.)	73 kg. (161 lb.)		
Shipping Carton Size	H 565 (22 1/4")	W 768 (30 1/4")	D 667 (26 1/4")

AIA File #:

Specifications

Commercial microwave 10 touch pad control panel shall be programmable with the ability to program up to 100 menu items and shall have automatic cooking capability for up to two servings. Cooking timer shall be no more than 60 minutes, countdown style with a time entry option and an adjustable end of cycle audible signal. LCD display shall be a backlit. There shall be 11 power levels, 4 cooking stages and defrost mode at 20% power. Microwave output shall be 3500 watts distributed by four magnetrons, each with a rotating antenna to provide even heating throughout the cavity. Heavy duty door shall have a tempered glass window and a pull down door for easy access. An interior light shall facilitate monitoring without opening the door. The large 45 liter (1.6 cubic ft.) cavity shall accommodate two standard 102 mm (4") deep full sized pans. Interior ceramic shelf shall be recessed to reduce plate-to-shelf edge impact. Oven shall have a stainless steel interior and exterior and be stackable to save counter and shelf space. Oven shall have a "clean filter" reminder feature Microwave oven shall comply with standards set by the U.S Department of Health and Human Services, ETL for safety and sanitation.

Warranty

Warranty Certificate for this product can be found on the ACP, Inc. website at: www.acpsolutions.com/warranty



Measurements are in millimeters

* IEC 60705 Tested

** Includes handle